

Duct top-hat rail air flow sensor or measuring transducer for flow velocity and volume flow, electronic, external flow probe incl. mounting flange, calibratable, with Modbus connection

Electronic duct top-hat rail air flow sensor RHEASGARD® KHSSFV-Modbus with Modbus connection, housing for installation in distributor boxes or control cabinets with 35 mm mounting rail, external flow probe incl. mounting flange, for determining the flow velocity (0.1...20 m/s). The following parameters can be retrieved from the Modbus: Flow velocity and volume flow (calculated).

The flow sensors is suitable for monitoring or controlling airflows in ducts, at fans and dampers, for flow-dependent monitoring of humidifiers and electric heating registers according to DIN 57100, Sect. 420, or for use in connection with DDC systems.

Innovative Modbus sensor with galvanically isolated RS485 Modbus interface, switchable bus terminating resistance, DIP switch for setting the bus parameters and bus address in current-free state, LEDs for telegram status display. The sensor is factory-calibrated.

TECHNICAL DATA

| | |
|----------------------|--|
| Power supply: | 24 V AC / DC (± 10 %) |
| Current consumption: | approx. 4 VA |
| Data points: | Flow velocity [m/s], volume flow [m³/h] |

AIR FLOW

| | |
|----------------------|---|
| Sensor: | calorimetric, temperature compensated, sensor breakage protection |
| Measuring range: | 0.1...20 m/s |
| Accuracy: | ± 0.5 m/s + max. ± 3% of final value (22°C, 50% RH, 1013 mbar) |
| Long-term stability: | ± 0.5 % of final value per year |
| Reproducibility: | ± 1.0 % of final value |
| Warm up time: | < 2 min |
| Response time: | < 5 s |
| Start-up override: | 20 m/s for 60 s (after applying the supply voltage) |
| Medium: | non-precipitating air free of harmful substances, without below- and/or above-pressure |
| Medium temperature: | 0...+70 °C |

GENERAL

| | |
|---------------------------------|--|
| Communication: | Modbus (RTU cable) |
| Bus interface: | RS485, galvanically isolated |
| Baud rate: | 9600, 19200, 38400 Baud |
| Bus protocol: | Modbus (RTU mode), address range 0... 247 selectable |
| Signal filtering: | 0...30 values |
| LED operating status indicator: | Green LED [ok] error-free protocol received Red LED [err.] protocol or checksum contains errors |
| Housing: | PC / ABS (UL94-V0) material, light grey colour, 36 mm (2TE) wide for 35 mm mounting rail, approx. 90 x 36 x 58 mm (HxWxD) |
| Probe/sensor: | Polyamide (PA6) material, white colour (blue sensor holder), with torsion protection, Ø 12 mm, EL = approx. 20–155 mm, v _{max} = 20 m/s (air) |
| Sensor cable: | PVC LiYY, 3-wire, KL = approx. 2.4 m |
| Electrical connection: | 0.14–2.5 mm², via screw terminal |
| Process connection: | by means of mounting flange with seal (included in the scope of delivery) |
| Ambient temperature: | Storage –20...+50 °C; operation 0...+50 °C |
| Permitted humidity: | < 98 % RH, non-precipitating air |
| Protection class: | III (according to EN 60 730) |
| Protection type: | IP 30 (according to EN 60 529) housing IP 20 (according to EN 60 529) probe |
| Standards: | CE conformity according to EMC Directive 2014 / 30 / EU |

ACCESSORIES see last chapter

Connection diagram KHSSFV-Modbus

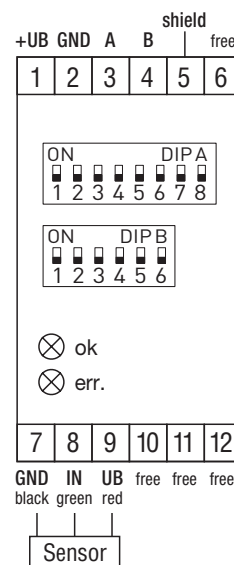

Note:
To set the internal DIP switches, the housing cover must be removed.

Mounting diagram KHSSFV-Modbus

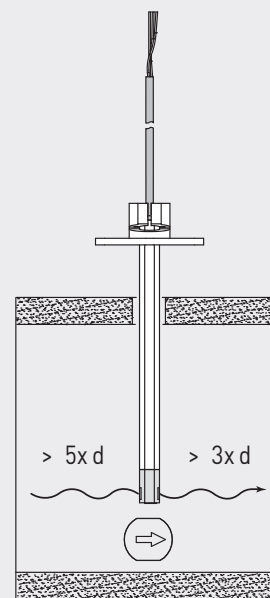

Note for mounting:
Sensor works unidirectionally. Observe the markings for the direction of flow!





NEW

S+S REGELTECHNIK

RHEASGARD® KHSSFV-Modbus

Duct top-hat rail air flow sensor or measuring transducer for flow velocity and volume flow, electronic, external flow probe incl. mounting flange, calibratable, with Modbus connection

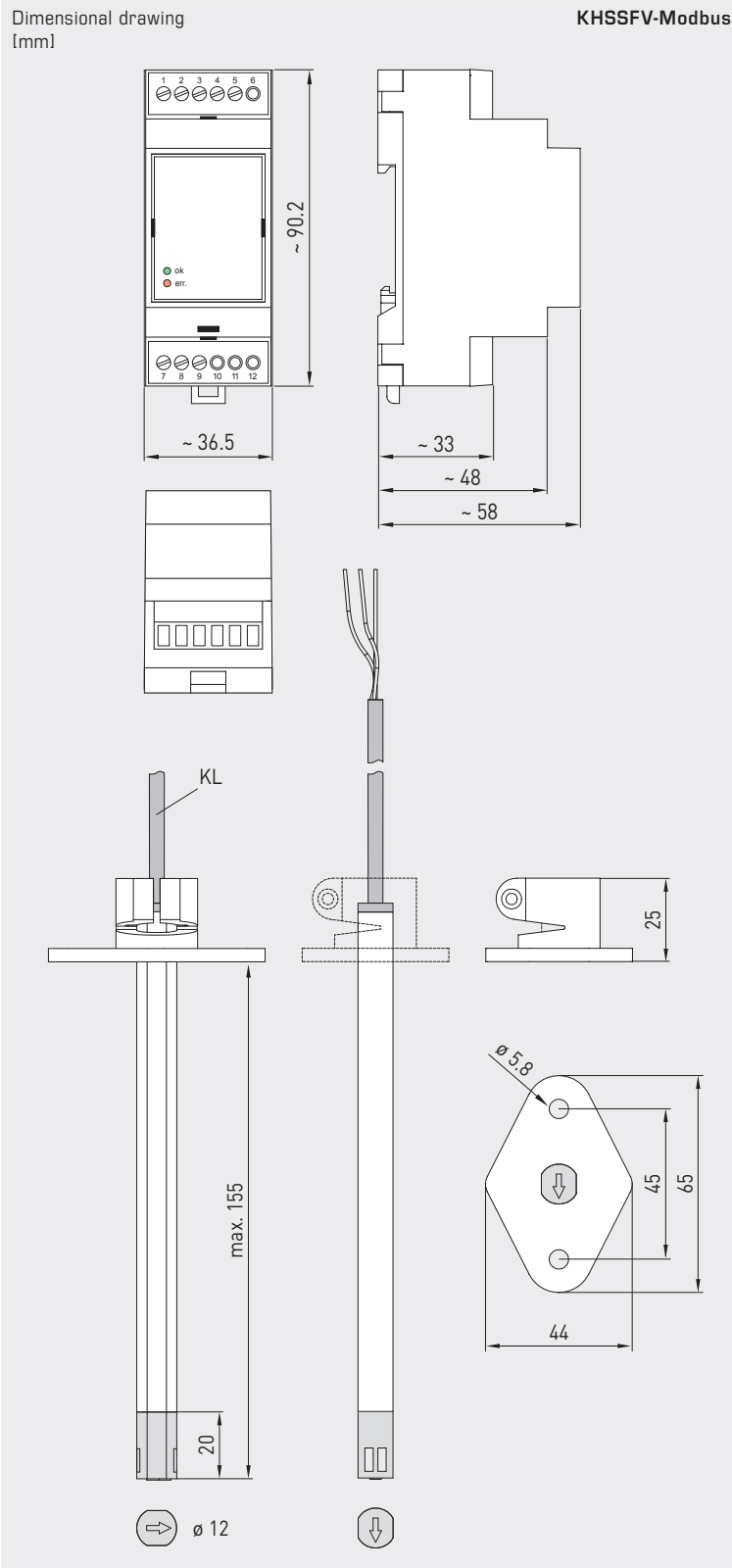

KHSSFV-Modbus Housing



KHSSFV-Modbus Probe



| RHEASGARD® KHSSFV-Modbus Duct top-hat rail air flow sensor or measuring transducer for flow velocity and volume flow, Deluxe | | | | |
|--|------------------|--------|--------------------|----------|
| Type / WG01 | Measuring ranges | Output | Item no. | Price |
| | Flow velocity | | | |
| | Volume flow | | | |
| KHSSFV-Modbus | | | | |
| KHSSFV-Modbus | 0.1...20 m/s | Modbus | 1701-5216-0302-000 | 385,07 € |