

THERMASGARD® ALTM1 - Modbus - T3

THERMASGARD® ALTM1 - wModbus



Surface-contact temperature measuring transducer / pipe surface-contact sensor
incl. strap, compact variant, calibratable,
with Modbus connection or W-Modbus (wireless)

S+S REGELTECHNIK

Calibratable surface-contact temperature measuring transducer (compact variant) **THERMASGARD® ALTM1 - Modbus - T3** with Modbus connection, in an impact-resistant plastic housing with quick-locking screws, pipe feeder, incl. strap, optionally with/without display, measures temperature (-50...+150 °C). International system of units **SI** (default) can be changed to **imperial** (via Modbus). With **wModbus** device version, the W-Modbus (Wireless) replaces the RTU cable; the BMS connection is radio-based using a W-Modbus gateway.

The pipe surface-contact sensor is used to detect the temperature on lines, pipes (e.g., cold and warm water) or on heating sections for heating control.

Innovative Modbus sensor with galvanically isolated RS485 Modbus interface, switchable bus terminating resistor, DIP switch for setting in current-free state, internal LEDs for telegram status display, push-in terminals and large three-line display (illuminated, individually programmable). Uses **internal diagnostics** to detect sensor breakage or sensor short circuit as errors. The sensor is factory-calibrated; an environmental precision adjustment by an expert is possible.

ALTM1 - Modbus - T3
without display
(RTU cable)



TECHNICAL DATA

Power supply:	24 V AC (± 20%); 15...36 V DC
Power consumption:	< 1.2 W / 24 V DC; < 1.8 VA / 24 V AC
System of units:	SI (default) or Imperial (switchable via Modbus)
Data points:	Temperature [°C] [°F]
Sensor:	Pt1000, DIN EN 60751, class B
Measuring range:	-50...+150 °C, T_{max} at +100 °C (compact variant)
Accuracy, temperature:	typically ± 0.2 K at +25 °C
Zero point offset:	± 10 °C
Ambient temperature:	Measuring transducer -30...+70 °C
Medium:	clean air and non-aggressive, non-combustible gases
Communication:	Modbus (RTU cable), Bus interface RS 485, galvanically isolated , Baud rate 9600, 19200, 38400 baud or W-Modbus (Wireless Modbus, AES-128 encrypted) Frequency 2.4 GHz ISM, Transmission power 100 mW , Range max. 500 m (open field) / approx. 50-70 m (inside buildings)
Bus protocol:	Modbus (RTU mode), address range 0... 247 adjustable
Signal filtering:	0,3 s / 1 s / 10 s
Housing:	Plastic, UV-resistant, material polyamide, 30 % glass-globe reinforced, with quick-locking screws (slotted / Phillips head combination), colour traffic white (similar to RAL 9016), housing cover for display is transparent!
Housing dimensions:	108 x 78.5 x 43.3 mm (Tyr 3 without display) 108 x 78.5 x 45,8 mm (Tyr 3 with display)
Cable connection:	Cable gland , plastic (M20 x 1.5; with strain relief, exchangeable, inner diameter 8 - 13 mm) or M12 connector according to DIN EN 61076-2-101 (optional on request)
Electrical connection:	0.2 - 1.5 mm ² , using push-in terminals
Process connection:	endless strap with metal tightener (included in scope of delivery) Ø = 13-92 mm (¼ - 3"), L = 300 mm
Permissible air humidity:	< 95 % RH, non-precipitating air
Protection class:	III (according to EN 60 730)
Protection type:	IP 65 (according to EN 60 529)
Standards (Modbus):	CE conformity according to EMC Directive 2014 / 30 / EU
Standards (W-Modbus):	CE conformity according to Radio Directive 2014 / 53 / EU
Features:	Display with illumination , three-line, programmable, cutout approx. 51 x 29 mm (W x H), for displaying the actual temperature, error message or an individually programmable display value
Internal diagnostics:	Error 1 at sensor breakage Error 2 at sensor short circuit

ALTM1 - wModbus
without display
(wireless)



Programmable display screen **Tyr 3**





NEW

S+S REGELTECHNIK

THERMASGARD® ALTM1 - Modbus - T3

THERMASGARD® ALTM1 - wModbus

Surface-contact temperature measuring transducer / pipe surface-contact sensor
incl. strap, compact variant, calibratable,
with Modbus connection or W-Modbus (wireless)

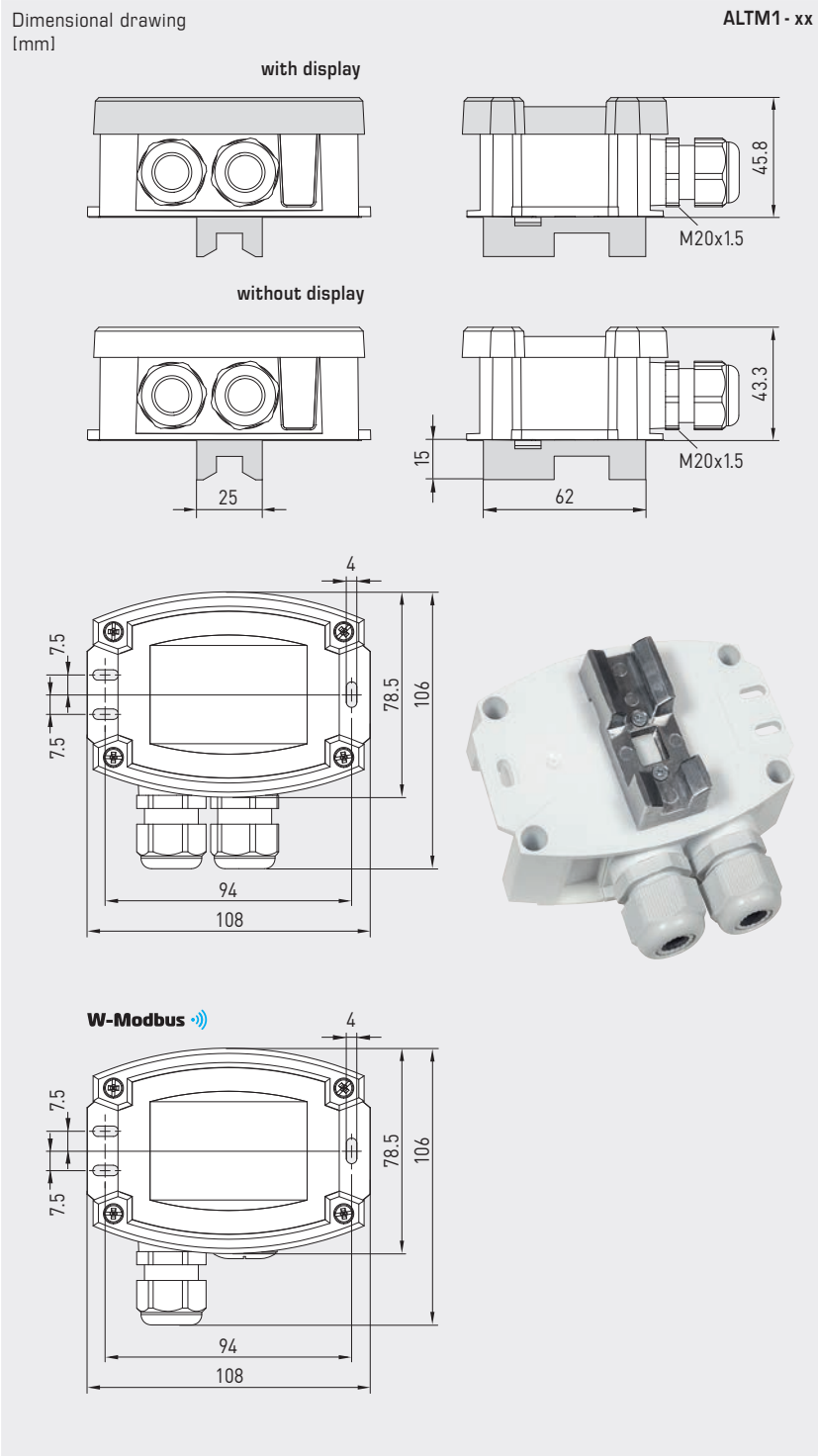

ALTM1 - Modbus - T3
with display
(RTU cable)



ALTM1 - wModbus
with display
(wireless)



Device version
with **M12 connector**
(optional on request)



THERMASGARD® ALTM1 - Modbus-T3

THERMASGARD® ALTM1 - wModbus



Surface-contact temperature measuring transducer / pipe surface-contact sensor
 incl. strap, compact variant, calibratable,
 with Modbus connection or W-Modbus (wireless)

S+S REGELTECHNIK

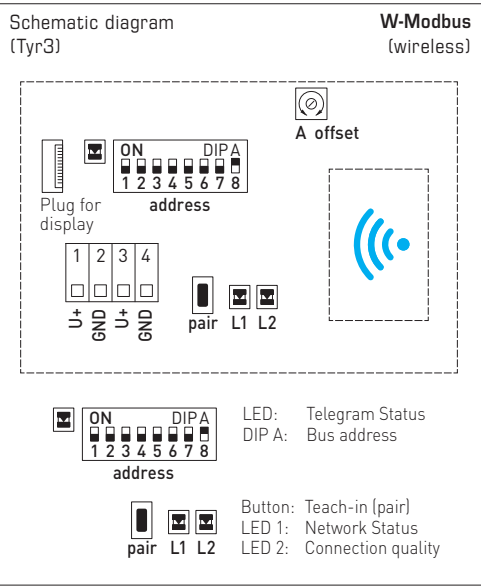
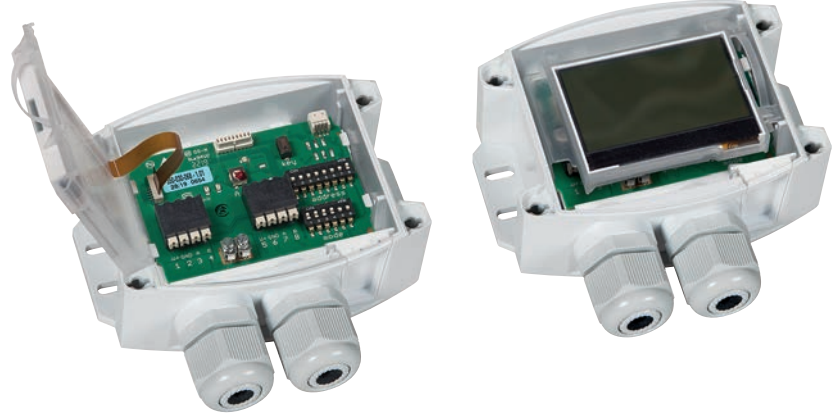
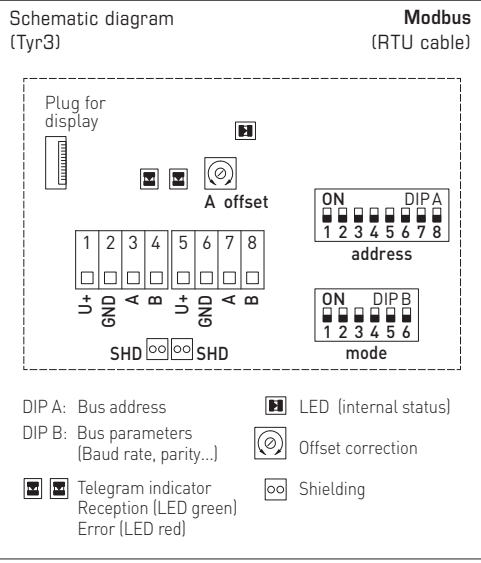

GW-wModbus (Pro)
 Gateway with W-Modbus module,
 for radio-based connection to Modbus networks





NEW

S+S REGELTECHNIK

THERMASGARD® ALTM1 - Modbus - T3 THERMASGARD® ALTM1 - wModbus

Surface-contact temperature measuring transducer / pipe surface-contact sensor
incl. strap, compact variant, calibratable,
with Modbus connection or W-Modbus (wireless)

ALTM1 - wModbus
with / without display
(wireless)



ALTM1 - Modbus - T3
with / without display
(RTU cable)



THERMASGARD®
ALTM1 - Modbus - T3
ALTM1 - wModbus

Surface-contact temperature measuring transducer /
pipe surface-contact sensor with Modbus connection (RTU cable) or
with W-Modbus (wireless)



Type / WG01	Output	Type	Display	Item No.	Price
ALTM1-xx					
ALTM1-Modbus-T3	Modbus (RTU cable)	compact		1101-12B6-0000-000	189,81 €
ALTM1-Modbus-T3 LCD	Modbus (RTU cable)	compact	■	1101-12B6-4000-000	251,07 €
ALTM1-wModbus	W-Modbus (wireless)	compact		1101-12BF-0000-000	232,66 €
ALTM1-wModbus LCD	W-Modbus (wireless)	compact	■	1101-12BF-4000-000	293,92 €
Extra charge:	able connection with M12 connector according to DIN EN 61076-2-101			on request	
Note:	System of units SI (default) or imperial (can be changed via Modbus).				

MODBUS ACCESSORIES

GW-wModbus	Gateway with W-Modbus (Wireless) for radio-based connection to Modbus networks, operating modes ' Gateway ' (basic function as a base station) and ' Node ' (adapter function for max. 1 wired sensor)	1801-1211-1101-000	245,30 €
GW-wModbus Pro	and ' Node Pro ' (adapter function for max. 16 wired sensors)	1801-1211-1101-100	332,07 €
KA2-Modbus	Communication adapter (USB/RS485) for system connection	1906-1200-0000-100	236,11 €
LA-Modbus	Line termination device (with terminating resistor) as an active bus termination	1906-1300-0000-100	88,05 €

For further information see the end of the chapter!

ACCESSORIES

WLP-1	Heat-conductive paste , silicone-free	7100-0060-1000-000	5,13 €
--------------	--	--------------------	--------

For further information, see last chapter Accessories!